

PARTS BOOK

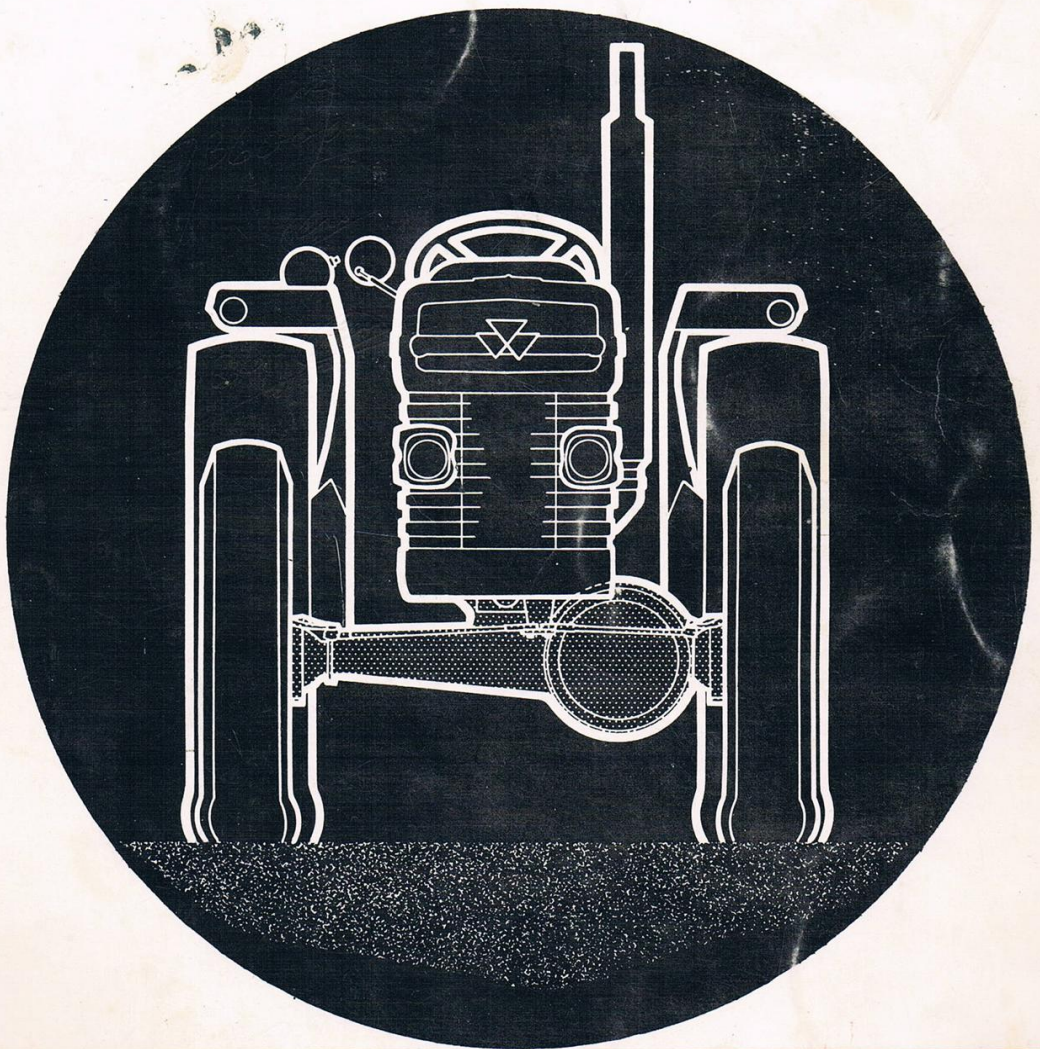

**Four Wheel Traction conversion
for Massey Ferguson 188, 185, 168,
165 178,**

JULY 1973



FOUR WHEEL TRACTION LIMITED

15 NORTH AUDLEY STREET, LONDON W1Y 2LR

Telephone 01-629 9966

PARTS BOOK

When ordering parts please always quote:

- 1 Your Order Number
- 2 Tractor type and Serial Number
- 3 4 WT Kit Number
- 4 4 WT Part Number

Refer to Left or Right Hand when facing forwards, i.e. driving position.

Subject to change or modification at any time without notice

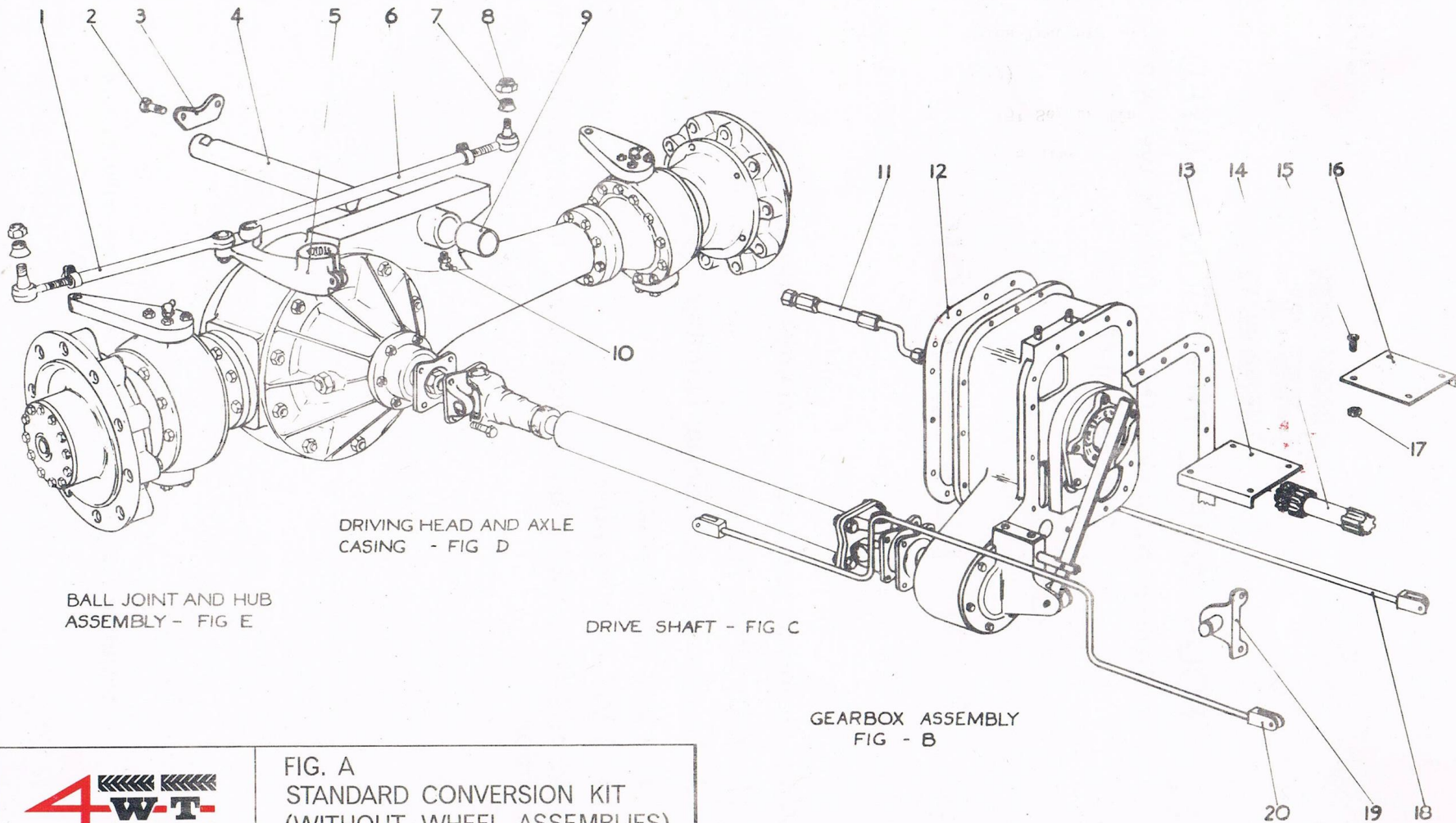

4W-T

FIG. A
STANDARD CONVERSION KIT
(WITHOUT WHEEL ASSEMBLIES)

MF 165 & 178

FIG 'A'

Key No.	Part No.	No. Req'd.	Description
1	S1919A	1	TRACK ROD - L.H.
2	C1317/1181	2	BOLT /SPRING WASHER
3	C2095	1	RETAINER PLATE
4	C2059	1	PIVOT PIN
5	C1655	1	STEERING ARM (not supplied)
6	S1919B	1	TRACK ROD - R.H.
7	C1566	4	BOOT
8	C1555	4	NUT
9	C1141	2	BUSH
10	C1467		GREASE NIPPLE
11	C2445	1	MULTIPOWER HOSE (15 ¹ Series Tractors only)
12	C1550	2	GASKET
13	C2155	1	FOOTPLATE EXTENSION - L.H. (15 ¹ Series Tractors only)
14	C2437	1	REAR MAINSHAFT (18 ¹ Series Tractors only)
15	C2445/1181	4	BOLT /SPRING WASHER (15 ¹ Series Tractors only)
16	C2155	1	FOOTPLATE EXTENSION - R.H. (15 ¹ Series Tractors only)
17	C1791	4	NUT (15 ¹ Series Tractors only)
18	C2441	1	FOOTBRAKE LINK ROD (15 ¹ Series Tractors only)
19	C2442	1	CLUTCH PEDAL BRACKET (15 ¹ Series Tractors only)
20	C2440	1	FOOTBRAKE LINK ROD

FIG A

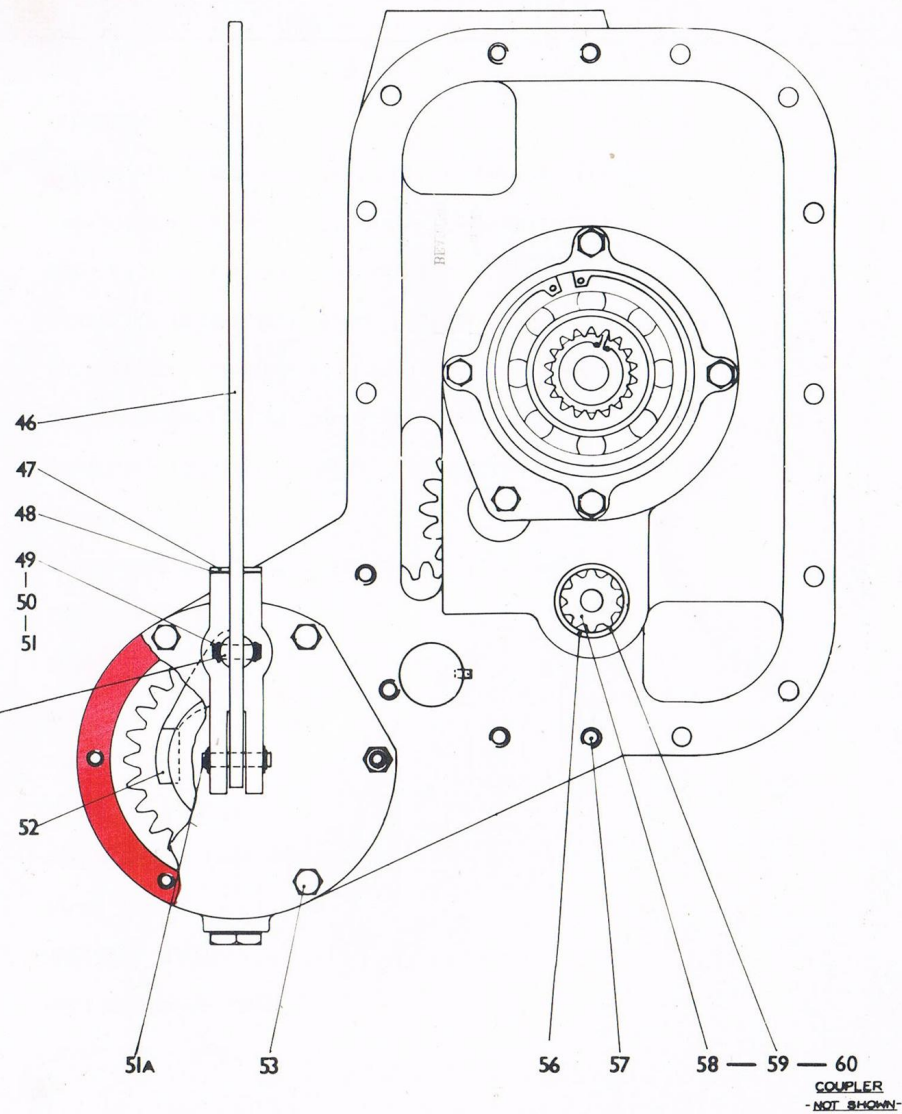
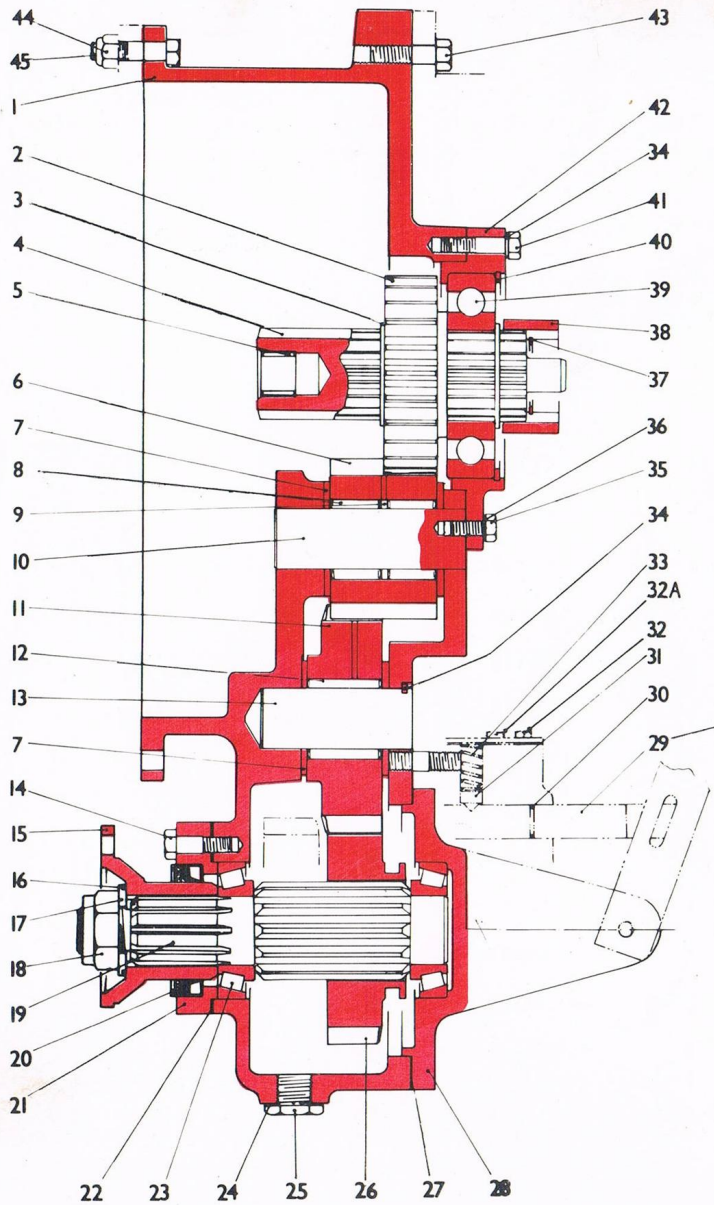

FIG. B
 SANDWICH GEARBOX (2400 SERIES)
 MF 165 & 178

COUPLER
 NOT SHOWN

Key No.	Part No.	No. Req'd.	Description	Key No.	Part No.	No. Req'd.	Description
1	C2401	1	GEARCASING	51	C1806	1	PLUNGER
2	(C1859	1	INPUT GEAR 24 TEETH	52	C1319/1082	1	SCREW /SPRING WASHER
	C2416	1	INPUT GEAR 25 TEETH	32A	C2446/1167	1	SCREW/SPRING WASHER
	(C2417	1	INPUT GEAR 22 TEETH	53	C1644	1	SPRING
3	C1860	2	RETAINER RING	54	C2435	1	PIN
4	C2413		MAINSHAFT	55	C2447	1	SCREW
5	C1286	1	NEEDLE ROLLER BEARING	56	C1082	1	WASHER
6	(C1605	1	IDLER GEAR 19 TEETH	57	C2418	1	CIRCLIP
	C2430	1	INTERMEDIATE GEAR 19/18 TEETH	58	C2404	1	COUPLER
	(C2429	1	INTERMEDIATE GEAR 19/17 TEETH	59	C2405	1	BEARING
7	C1607	4	THRUST WASHER	40	C2444	1	CIRCLIP
8	C1608	44	NEEDLE ROLLER	41	C2419	3	BOLT
9	C1612	1	SPACER	42	C2402	1	BEARING HOUSING - INPUT
10	C2405	1	SHAFT	43	C1160	2	BOLT
11	C1609	1	IDLER GEAR	44	C1046/1045	24	BOLT /SPRING WASHER
12	C1611	22	NEEDLE ROLLER	45	C1551	24	NUT
13	C2406	1	SHAFT	46	C1646	1	LEVER
14	C1081 /1082	1	BOLT /SPRING WASHER	47	C2412	1	PLATE
15	C1165	1	COMPANION FLANGE	48	C2425	1	GASKET
16	C1634	1	'O' RING	49	C1133	4	WASHER
17	C1633	1	WASHER	50	C1585	4	RETAINER
18	C1671	1	NUT	51	C2421	1	PIN - UPPER
19	C1627	1	SHAFT - OUTPUT	51A	C2420	1	PIN - LOWER
20	C1670	1	OIL SEAL	52	C1304	1	ENGAGEMENT FORK
21	C1650	1	SEAL HOUSING	53	C1616 /1082	6	BOLT/SPRING WASHER
22A	(C1631A	A/R	SHIM .005"				
	C1631B	A/R	SHIM .007"				
	(C1631C	A/R	SHIM .010"	57	C2415	4	STUD
23	C1628	2	TAPER ROLLER BEARING	58	C2438	1	P.T.O. SHAFT
24	C1564	1	SEALING WASHER	59	C2439	1	BEARING
25	C2448/1158	1	DRAIN PLUG /SPRING WASHER	60	C2016	1	COUPLER
26	(C2078	1	OUTPUT GEAR 27 TEETH				
	C1626	1	OUTPUT GEAR 28 TEETH	NOT ILLUSTRATED	C2449	1	COTTER PIN
	(C2424	1	OUTPUT GEAR 29 TEETH				
27	C2407	1	GASKET				
28	C2408	1	BEARING HOUSING				
29	C1315	1	ENGAGEMENT ROD				
30	C1613	1	'O' RING				

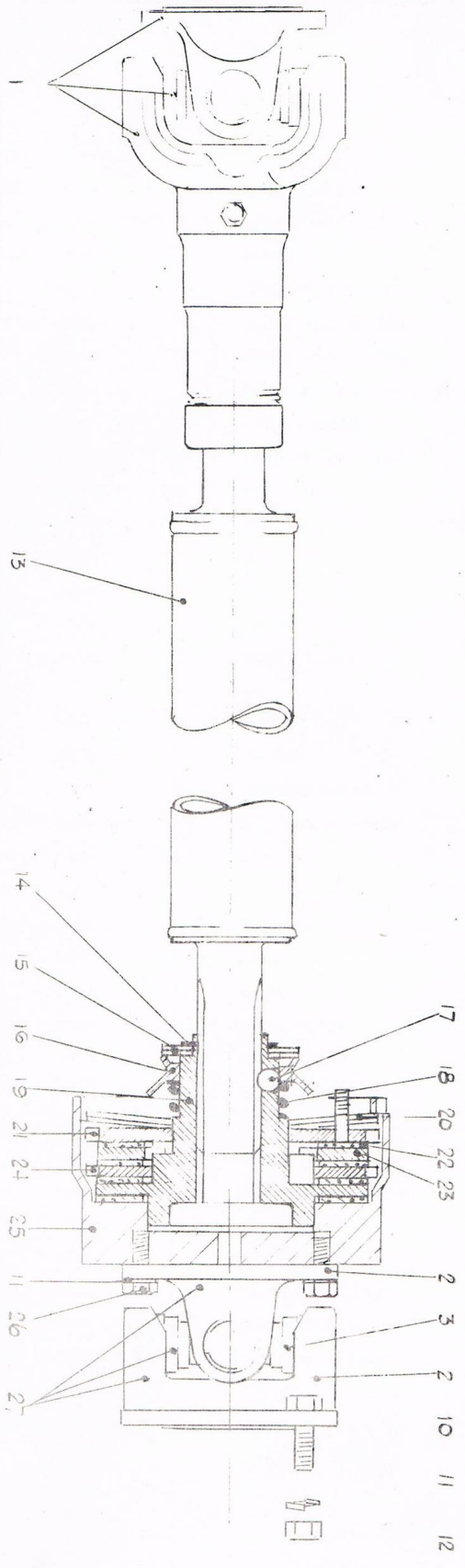
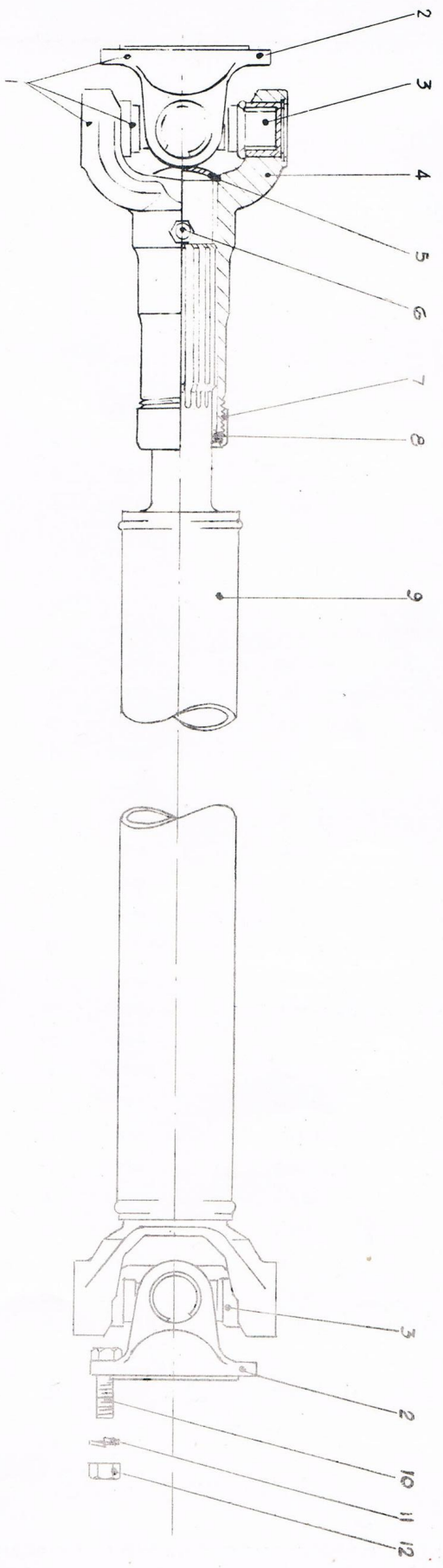

FIG. 5
DRIVE SHAFT / TORQUE CLUTCH

Key No.	Part No.	No. Req'd	Description	Key No.	Part No.	No. Req'd	Description
	A1507		PROP-SHAFT ASSEMBLY (165 TRACTOR)	17	C1641	3	BALL
	A1508		PROP-SHAFT ASSEMBLY (178 TRACTOR)	18	C2081	1	SPRING
			PROP-SHAFT ASSEMBLY WITH TORQUE LIMITING CLUTCH (165 TRACTOR)	19	C2087	1	HUB
			PROP-SHAFT ASSEMBLY WITH TORQUE LIMITING CLUTCH (178 TRACTOR)	20	C2084	2	PLATE SPRING
1	S1023	1	SLIP JOINT ASSEMBLY	21	C2083	1	REACTION PLATE (WITH STUDS)
2	C1689	2 or 3	FLANGE YOKE	22	C2086	4	FRICITION PLATE
3	C1681	2	SPIDER ASSEMBLY	23	C2085	1	REACTION PLATE (SPLINED BORE)
4	C1682	1	SLIDING YOKE	24	C2292	1	REACTION PLATE (KEYED OUTSIDE)
5	C1683	1	CAP	25	C2088	1	DRIVE CUP
6	C1684	2	GREASE NIPPLE	26	C2092	4	SCREW
7	C1685	1	SCREWED CAP	27	C1024	1	FLANGE YOKE ASSEMBLY
8	C1686	1	CORK RING				
9	S1678	1	TORQUE TUBE SUB-ASSEMBLY (165)				
or	S1679	1	TORQUE TUBE SUB-ASSEMBLY (178)				
10	C1495	8	BOLT				
11	C1045	8 or 12	SPRING WASHER				
12	C1551	8	NUT				
13	C1915	1	TORQUE TUBE SUB-ASSEMBLY (165)				
or	C1914	1	TORQUE TUBE SUB-ASSEMBLY (178)				
	C1916	1	TORQUE LIMITING CLUTCH COMPLETE				
14	C2079	1	CIRCLIP				
15	C2080	2	THRUST WASHER				
16	C2082	1	COLLAR				

4-W-T

FIG. D
AXLE CASING AND DRIVING HEAD

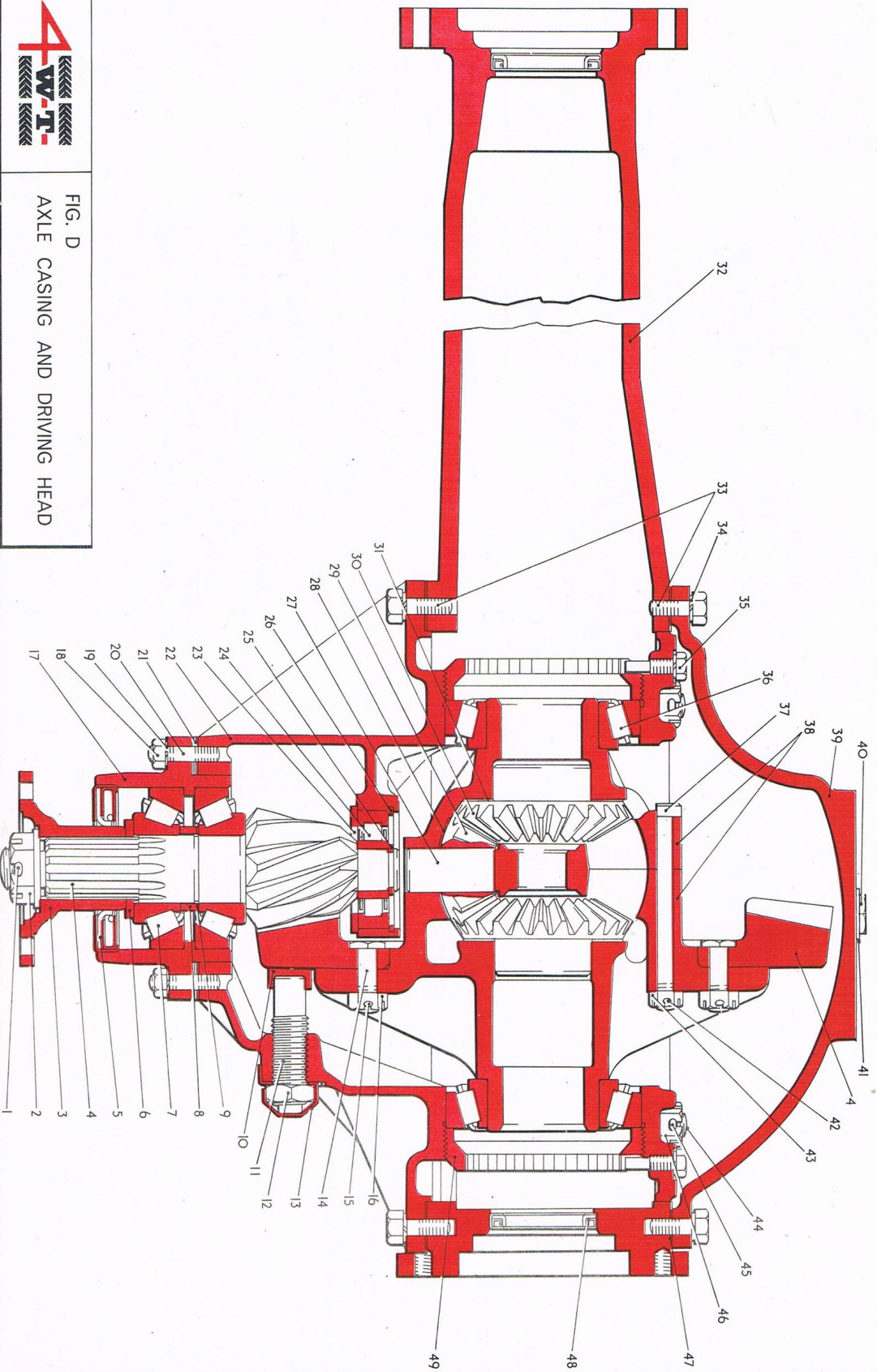

FIG. E.

Key No.	Part No.	No. Req'd	Description	Key No.	Part No.	No. Req'd	Description
1	C1519	2	GASKET	37	C1480	2	COVER
2	C1453	2	BALL JOINT	38	C1476	2	DOWEL
3	C1457	2	'TRACTA' JOINT MALE	39	C1387	2	ROLLER BEARING
4	C1234	2	OIL SEAL	40	C1477	2	CIRCLIP
5	C1468	2	BOLT	41	C1082	20	SPRING WASHER
6	C1045	6	SPRING WASHER	42	C1179	20	BOLT
	C1583	4	DOWEL BOLT (NOT SHOWN)	43	C1886	1	STEERING ARM LEFT
7	C1458	2	OIL SEAL HOUSING	43A	C1885	1	STEERING ARM RIGHT
8	C1460	4	BEARING SHAFT	44	C1475	8	STEERING ARM STUD
9	C1181	16	SPRING WASHER	45	C1177	14	SPRING WASHER
10	C1454	16	NUT	46	C1469	14	SCREW
11	C1467	4	GREASE NIPPLE	47	C1044	8	BOLT
12	C1374	A/R	SHIMS (GRADED)	48	C1045	16	SPRING WASHER
13	C1455	8	STUD	49	C1465	8	BOLT
14	C1463	2	CAP	50	C1044	8	NUT
15	C1456	2	BALL JOINT HOUSING	51	C1452	2	CIRCLIP
16	C1379	4	TAPER ROLLER BEARING	52	C1451	2	THRUST WASHER
17	C1484	2	'TRACTA' JOINT FEMALE	53	C1450	2	TAB WASHER
18	C1482	2	HUB	54	C1449	2	LOCK NUT
19	C1481	2	SEAL SEATING	55	C1388	2	BALL BEARING
20	C1479	2	SEAL	56	C1347	1	HALF SHAFT - LONG
21	C1392	2	TAPER ROLLER BEARING	56A	C1378	1	HALF SHAFT - SHORT
22	C1391	2	TAPER ROLLER BEARING				
23	C1485	2	THRUST WASHER				
24	C1486	4	NUT				
25	C1487	2	TAB WASHER				
26	C1045	24	SPRING WASHER				
27	C1202	24	FITTED BOLT				
28	C1492	2	DRIVING FLANGE				
30	C1483	2	STUB SHAFT				
31	C1491	2	SEALING WASHER				
32	C1181	2	SPRING WASHER				
33	C1494	2	BOLT				
34	C1490	2	CAP				
35	C1493	2	WHEEL FLANGE				
36	C1478	10	SCREW				

FIG E

STANDARD WHEEL ASSEMBLIES

Comprising:- Tyre, Tube, Rim, Discs and Bolt-up components.

ASSEMBLY NO.	TYRE SIZE	PLY RATING
--------------	-----------	------------

MANUALLY ADJUSTED WHEELS

A 1567	9 - 24	4
A 1568	9 - 24	8
A 1569	10 - 24	4
A 1570	10 - 24	6

WHEEL WEIGHTS

PART NO.	NO. PER SET	USED ON
C 1363	4	24 inch wheels

Component parts should be ordered by description. Please quote the wheel assembly number for which they are required.